

# XTERN FRONTIER ORTHOTIC KIT ORTHÈSE XTERN FRONTIER



**MEDIUM : 102100-SA-M**  
US SHOE SIZE / POINTURE  
7.5 US → 10.5 US Men

**LARGE : 102100-SA-L**  
US SHOE SIZE / POINTURE  
10.5US → 16US Men



PARTS LIST- XTERN ANTERIOR ORTHOTIC KIT, SIZE LARGE / MEDIUM			
Item	Qty	PRODUCT CODE	DESCRIPTION
A	1	202000-BA0-L 202000-BA0-M	MAIN BRACE BODY ASSEMBLY, SIZE <span style="background-color: yellow;">LARGE</span> / <span style="background-color: green;">MEDIUM</span>
B	1	200000-U00-ML	FRONT SHOE SECTION «U» SHAPE, MEDIUM-LARGE
C	1	202000-S00-M	SHIN ARCH SECTION
D	5	200000-L00-ML	LACE CLIP ATTACHMENT, SIZE MEDIUM-LARGE
E	3	700000-SET-002	SET SCREW 5-40 X 1/2" L. 18-8 STAINLESS STEEL
F	1	502400-K00-SML	SHIN PAD & MAGNET STRAP KIT
G	20	700000-ZZZ-001	TIE-WRAP BLACK 18 LBS/4" LONG
H	1	700000-HEX-001	HEX-L-KEY 1/16" (FOR 5-40 SET SCREW)
J	3	700000-SET-005	SET SCREW 5-40 X 5/16" L. 18-8 STAINLESS STEEL

REQUIRED TOOLS (NOT INCLUDED)	OUTILS REQUIS (NON INCLUS)	DRILL BIT / MÉCHE 7/64" (2.8 mm)

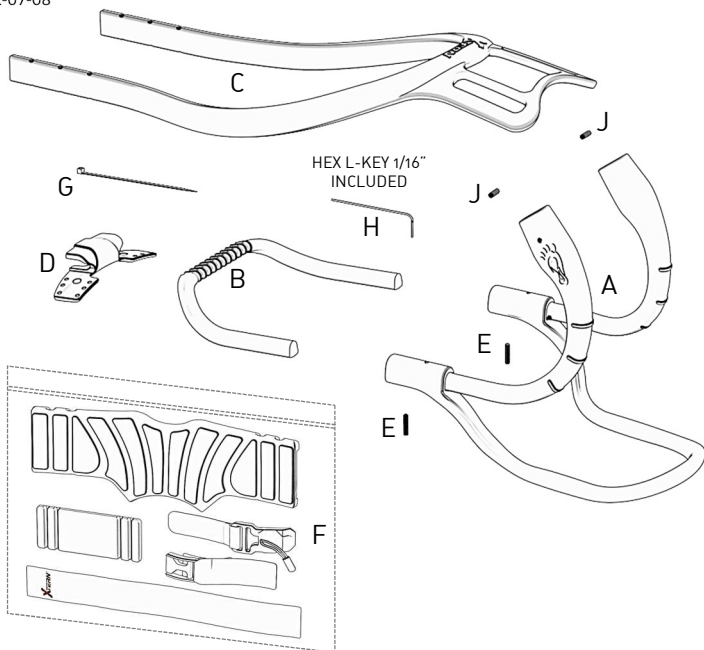

CUTTING CHART / CHARTE DE COUPE																		
US SHOE SIZE POINTURE US	GRANDEUR MEDIUM SIZE							GRANDEUR LARGE SIZE										
MEN / HOMME	7.5	8	8.5	9	9.5	10	10.5	11	11.5	12	12.5	13	13.5	14	14.5	15	15.5	16
WOMEN / FEMME	8.5	9	9.5	10	10.5	11	11.5	///	///	///	///	///	///	///	///	///	///	///
<b>X</b> CUTTING POSITION POSITION COUPE	<b>22</b>	<b>25</b>	<b>29</b>	<b>31</b>	<b>34</b>	<b>37</b>	<b>40</b>	<b>43</b>	<b>46</b>	<b>50</b>	<b>53</b>	<b>57</b>	<b>60</b>	<b>65</b>	<b>69</b>	<b>73</b>	<b>77</b>	<b>79</b>

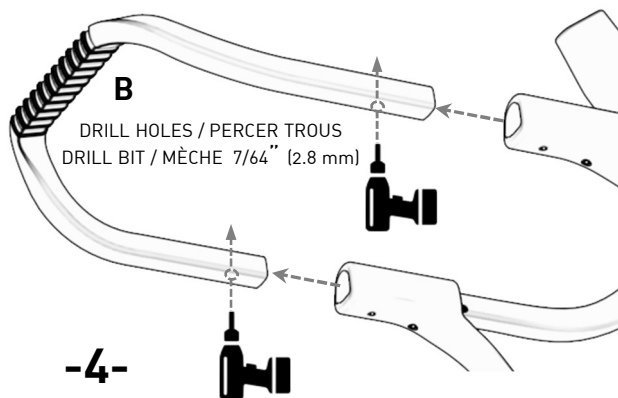
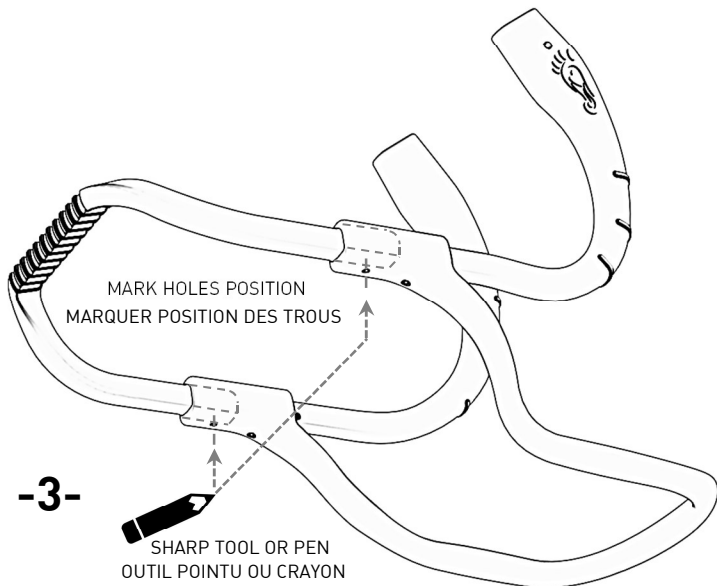
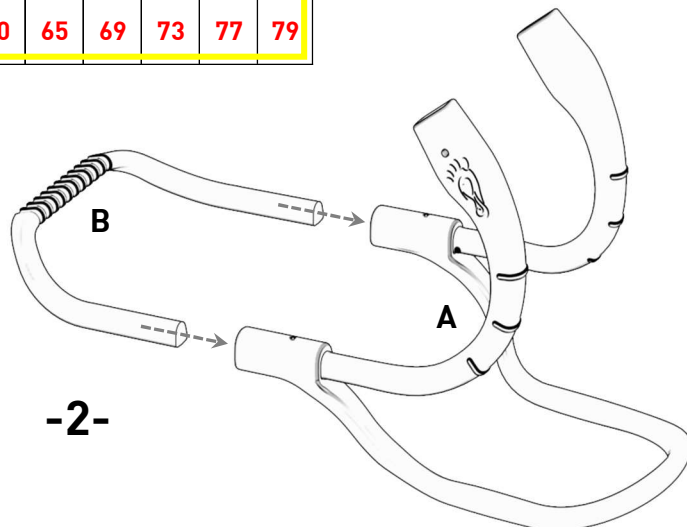
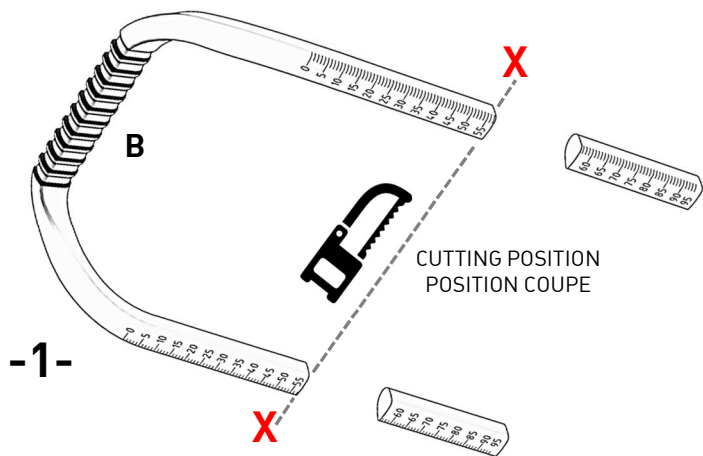

SHIN SUPPORT CUTTING CHART / CHARTE DE COUPE SUPPORT TIBIAL																		
US SHOE SIZE POINTURE US	GRANDEUR MEDIUM SIZE							GRANDEUR LARGE SIZE										
MEN / HOMME	7.5	8	8.5	9	9.5	10	10.5	11	11.5	12	12.5	13	13.5	14	14.5	15	15.5	16
WOMEN / FEMME	8.5	9	9.5	10	10.5	11	11.5	///	///	///	///	///	///	///	///	///	///	///
<b>H</b> CUTTING POSITION POSITION COUPE	<b>3</b>	<b>3</b>	<b>2</b>	<b>2</b>	<b>2</b>	<b>2</b>	<b>2</b>	<b>2</b>	<b>2</b>	<b>1</b>	<b>1</b>	<b>1</b>	<b>1</b>	<b>1</b>	<b>1</b>	<b>1</b>	<b>FULL</b>	<b>FULL</b>

-5-

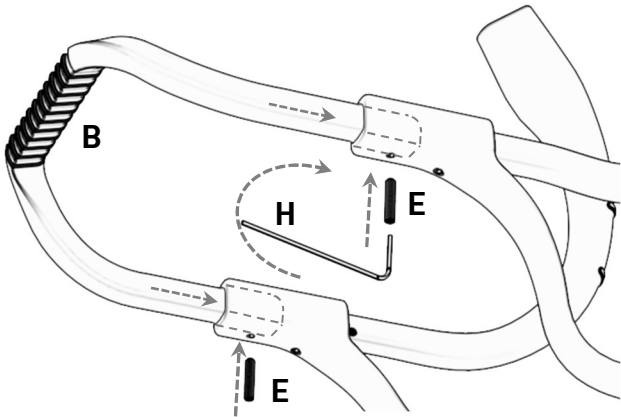

-6-

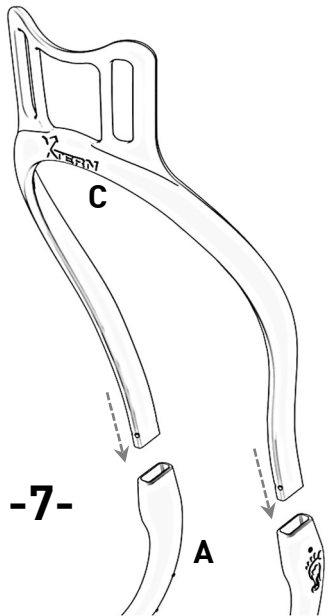
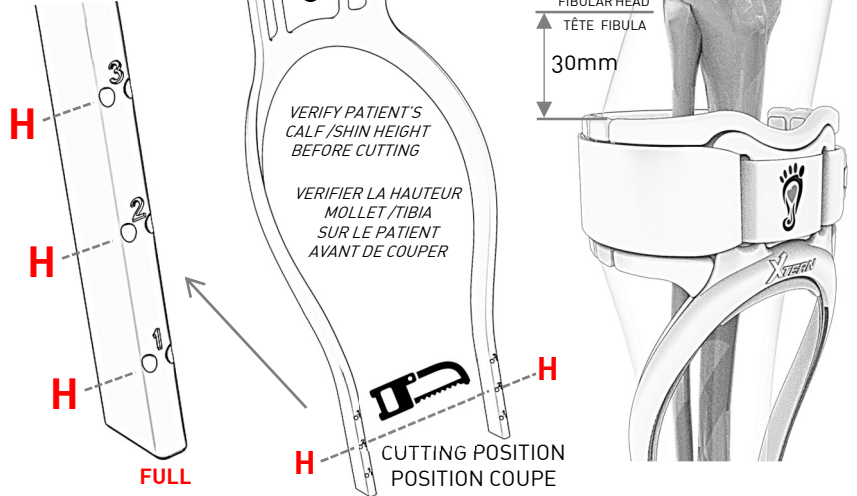

-7-

MARK HOLES  
MARQUER TROUS

SHARP TOOL OR PEN  
OUTIL POINTU OU CRAYON

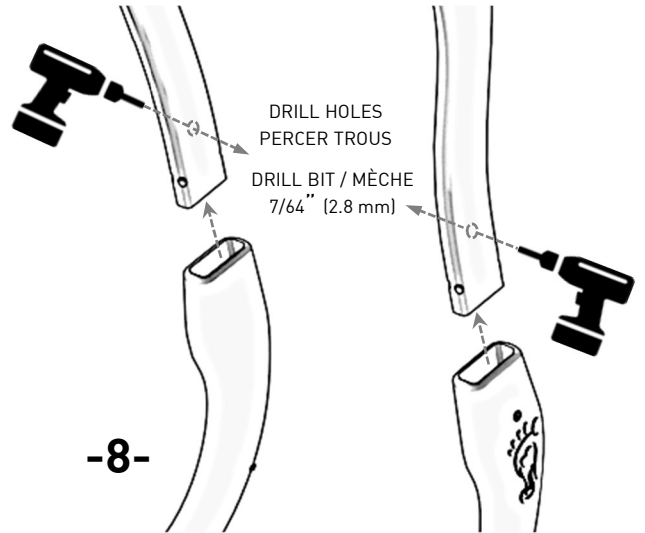

-8-

-9-

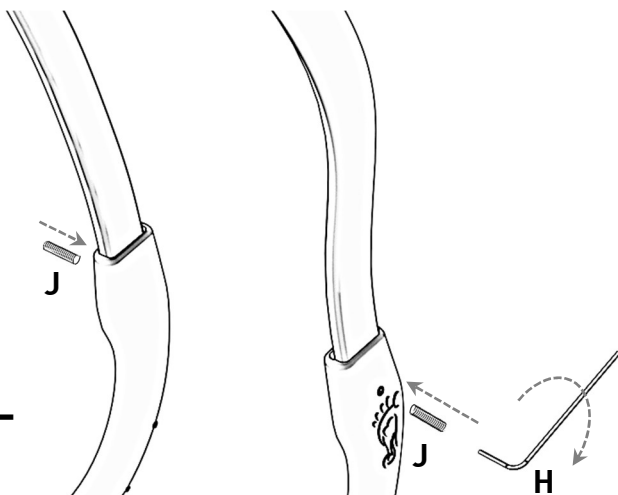

-10-

